

Power Solutions

- Telecom Power
- Server Power
- Electric Power
- Medical Power
- Display Power
- LED Power
- Laser Power
- OA Power
- Flat Panel Power
- Bi-directional Inverters for Portable Power
- Solar & BESS & EV Charging Solution

Industrial Automation

- Servo System
- Control System
- Elevator Controller
- Linear Motors
- IoT Solution
- Encoder
- Variable Frequency Drive
- Internal Gear Pump

eMobility & EV Infrastructure

- Integrated Charging System (OBC & DC-DC)
- E-Compressor
- TV EDU
- Inverter
- Thermal Mgmt. System
- Power Electronic Unit (2-in-1, 3-in-1)
- Construction Machinery Controller
- Railway A/C Controller
- Railway VFD
- Light Electric Vehicle Motors, Inverters, and Charging System

Intelligent Equipment

- Intelligent Welding
- Industrial Microwave
- Automatic Car Washing Machine
- Electric Submersible-Progressing Cavity Pump
- Polysilicon Water Quenching Equipment
- Intelligent Lifting Devices

Home Appliance Control Solutions

- Residential A/C Controller
- Vehicle A/C Controller
- Refrigerator Controller
- Industrial Microwave
- Commercial A/C Controller
- Solar A/C Controller
- Washer/Dryer Controller
- Smart Bidet
- Heat Pump Controller
- Mini Compressor Controller
- Residential Microwave
- RF Thawing System

Precision Connection

- FFC
- FPC
- Coaxial Cable
- CCS
- Litz Wire
- Peek Wire

SHENZHEN MEGMEET ELECTRICAL CO., LTD.

Add 1: 5th Floor, Block B, Unisplendour Information Harbor, Langshan Rd., Science & Technology Park, Nanshan District, Shenzhen, 518057, China

Add 2: 34th Floor, High-tech Zone Union Tower, No.63 Xuefu Road, Nanshan District, Shenzhen, 518057, China

FOLLOW US

Q Megmeet



Version: 202605

Megmeet reserves the right to modify the technical parameters and appearance of the products in this catalogue without prior advice to the users.

M3 Series Servo System



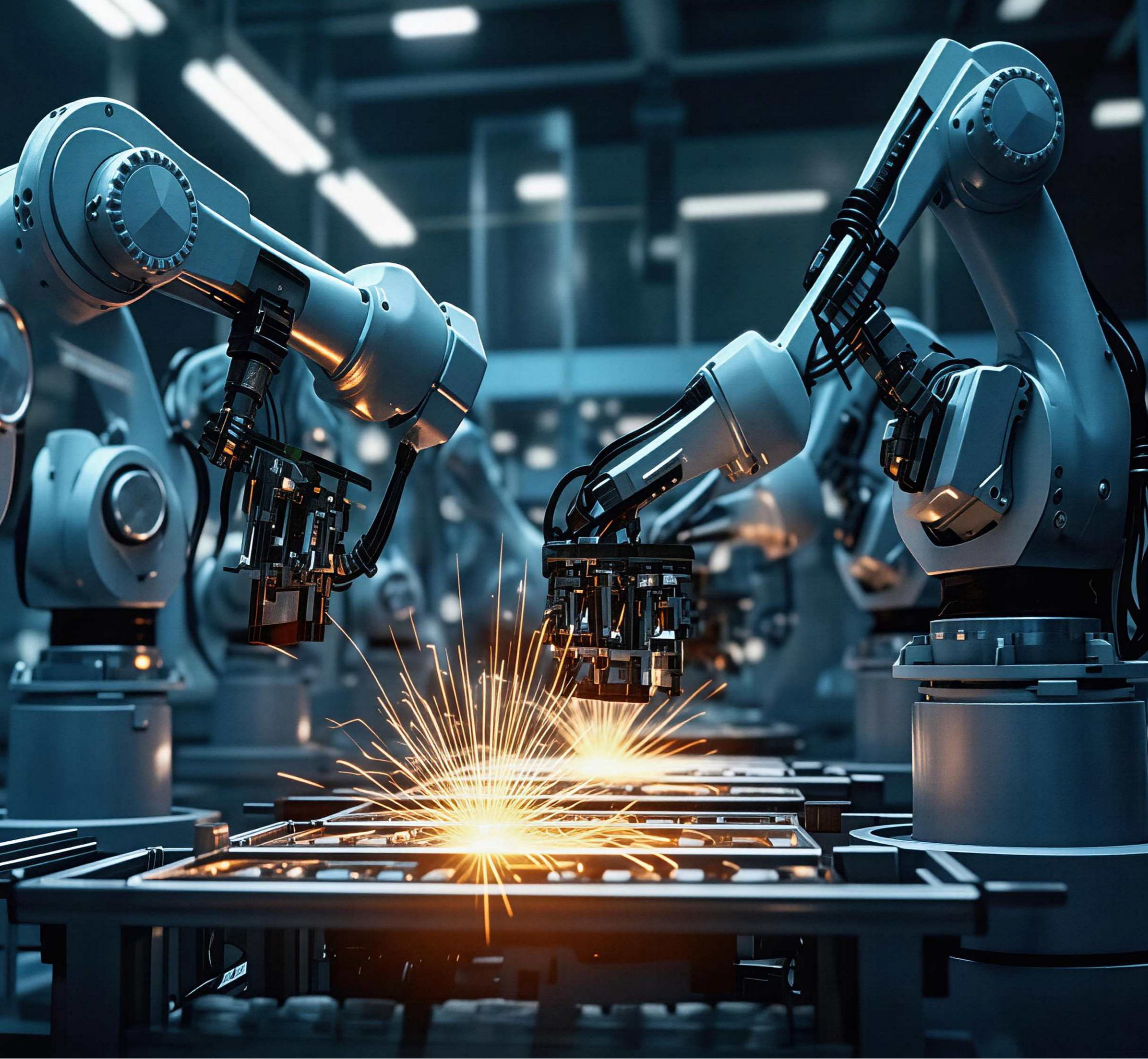

Contents

01	About MEGMEET
03	Servo Drive Introduction
05	Important Function
06	Host Computer Software
07	System Overview
08	Servo Drive Model and Specifications
09	Servo Motor Model and Cable Model
10	Servo System Configuration and Motor Specifications
11	M3-P General Specifications
12	M3-N General Specifications
13	M3-N Communication Specifications
15	M3-P Wiring
17	M3-N Wiring
19	Servo Motor Dimensions
21	Servo Drive Dimensions

ABOUT MEGMEET

MEGMEET is a comprehensive solution provider for hardware and software R&D, production, sales, and service in the field of electrical automation. With power electronics and automation control at its core, MEGMEET's main businesses include Power Solutions, Industrial Automation, emobility & EV Infrastructure, Intelligent Equipment, Home Appliance Control Solutions, and Precision Connection.

MEGMEET has established a robust R&D, manufacturing, marketing, and service platform, with over 13,000 employees, including more than 3,000 R&D staff worldwide. MEGMEET's global presence includes R&D Centers in China, the United States, and Germany; Manufacturing Centers in Thailand, India, the United States, and China; and Regional Offices across North America, South America, Europe, Central Asia, Northeast Asia, Southeast Asia, India, the Middle East, Oceania, and Africa.

MEGMEET is committed to creating a cleaner living environment for all human beings through more efficient energy utilization and improved manufacturing efficiency. MEGMEET aims to become the world leader in electrical automation and achieve the goal of MEGMEET EVERYWHERE.

 **3000+**
R&D Staff

 **10**
R&D Centers

 **9**
Manufacturing Bases

 **13000+**
Total Employees

 **1990+**
No. of Patents & IP Rights

R&D CAPABILITY

Sustainable R&D Investment

R&D Investment

R&D Employees
>3000 

Percentage against Total Employees
23% 

Percentage against Total Sales
>12% 

Patents & Industry Standards

No. of Patents & IP Rights
1990+
↑ 400+ new in 2024

National & International standards
32
● 9 lead author

Industry Standards Drafted
38
● 28 lead author

R&D Investment (in Millions of USD)

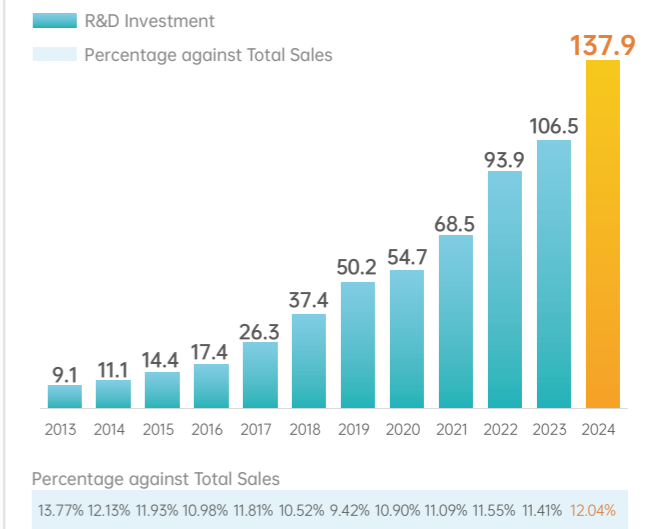

Testing Capabilities & Management System



MEGMEET's testing capabilities and management system have been certified by CNAS, TUV, UL-WTDP, and UL-CTF. MEGMEET's test results are recognized globally.



Introduction

Megmeet's new-generation M3 series servo system is featured with high response, high precision and high synchronization, and equipped with advanced functions such as online inertia identification, gain auto-tuning, vibration suppression, and quadrant compensation. Together with the intelligent Megmeet host controller, M3 is able to meet market requirements for mechanical equipment by high precision, high stability, high efficiency and ease of use.

High response

- Speed loop bandwidth 2.1 kHz
- High current loop and speed loop refresh frequency
- Faster response to commands
- High stiffness

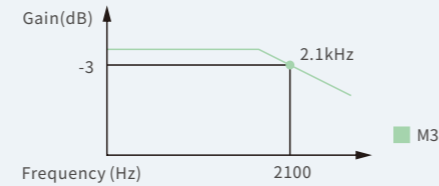

High overload

Overload capacity up to 3 times

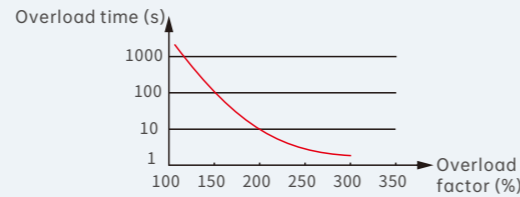

High bandwidth

- Input and output pulse up to 4 Mpps
- Supports differential and open-collector input
- Three pulse modes: A/B quadrature, direction + pulse and CW/CCW

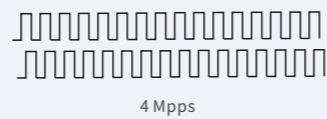

Optimized motor

- Smaller size with the same power, lowering mechanical installation requirements
- IP67 as the standard configuration, enhancing protection
- Better shock resistance of encoders
- Motors with various speeds

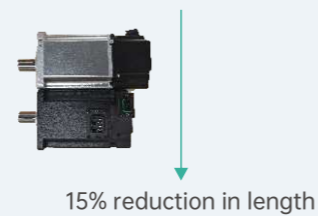

Power (W)	Motor	Frame	Length	Length (with brake)
400	SPM-SC*0604M*K-M (old)	60	112	152.5
	SPM-SC*0604M*K-H1 (new)	60	96	123

Increased power density of drive

- A solution with innovative design
- Smaller size, more compact structure
- Less installation space required in the electrical cabinet, facilitating installation and maintenance

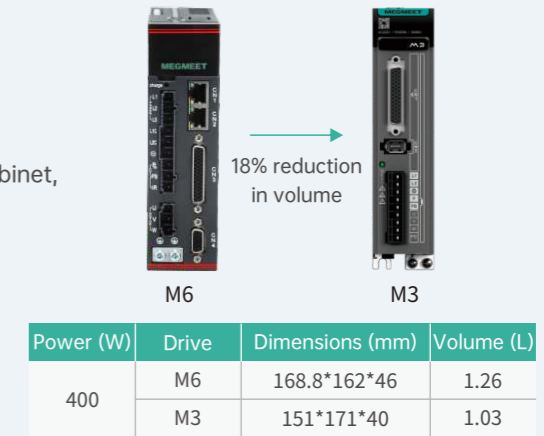

High precision encoder

- 17-bit multi-turn absolute magnetic encoder as the standard configuration
- The low-speed torque is more stable and the positioning is more accurate
- The motor still remains in its position after the servo unit is powered off

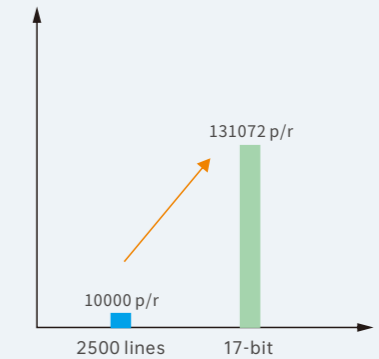

Installation of absolute encoder battery

- Easier to install/replace the battery
- Beautiful, neat, and less interference

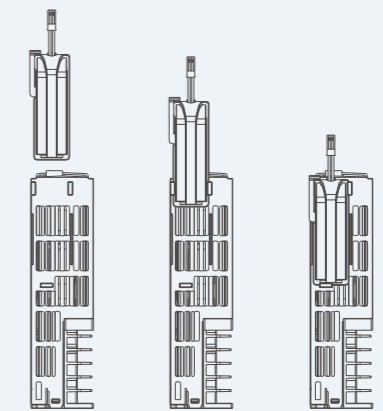

Important Function

Inertia identification

Both offline and online inertia identification can be performed. Through inertia identification, the load inertia ratio can be accurately obtained, which is helpful to complete the commissioning quickly and achieve the best control effect.

Gain adjustment

- Automatic gain adjustment: By selecting the stiffness level, matching gain parameters are automatically generated to meet the requirements of rapidity and stability.
- Manual gain adjustment: Manually fine-tune the gain to optimize the control effect.
- Speed feedforward: The function is used in the position control mode to reduce position following errors.
- Torque feedforward: In the position control mode, it can reduce the position deviation during acceleration and deceleration; and in the speed control mode, it can reduce the speed deviation when the speed is fixed.
- Multiple gain switchover modes

Torque disturbance observation

In a non-torque control mode, by detecting and estimating the external disturbance torque received by the system, the torque reference can be compensated to reduce the influence of external disturbance on the servo so as to reduce vibration.

High-frequency mechanical resonance suppression

Automatically search for high-frequency mechanical resonance frequency points, and reduce the gain at a specific frequency through 4 sets of notch filters, which can suppress mechanical resonance.

Low-frequency mechanical resonance suppression

For long-end mechanical loads, the low-frequency resonance suppression function can effectively reduce the end jitter caused by positioning completion or emergency stop.

Friction compensation

For loads with high friction, such as drive shafts of belts, friction compensation can shorten positioning time and reduce machining errors caused by friction.

Quadrant compensation

In the application of arc trajectory interpolation with more than 2 axes, quadrant compensation can reduce the arc distortion caused by friction non-linearity (the trajectory protrusion at the alternation of the four quadrants), and increase the accuracy of servo system control and the uniformity of motion.

Touch probe

Two high-speed touch probes.

Motor cogging torque compensation

Reduce the torque ripple caused by the cogging effect of motor, thus improving the stability of servo system.

Host Computer Software

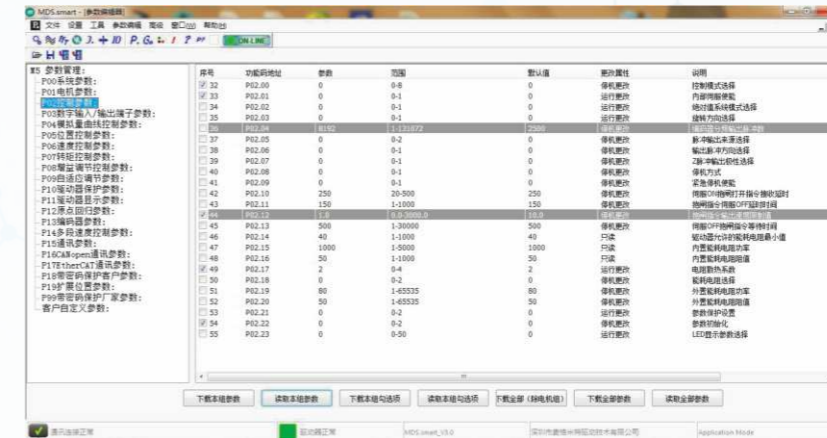

- Parameter auto-tuning
- Friendly HMI
- Shared USB port for firmware upgrade and host computer communication
- Centralized management: parameter upload & download and firmware upgrade of multiple drives
- Innovative power supply, parameter output and fault check through USB
- Blind matching supported for Type-C

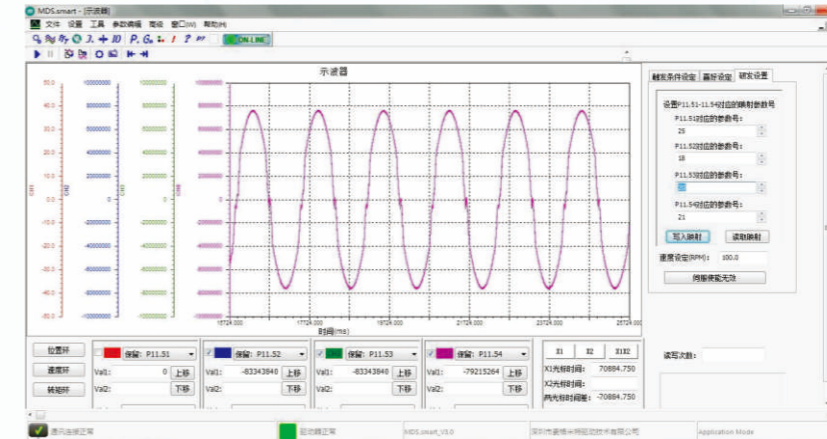

- Real-time online data monitoring with 32 bit * 4-channel real-time oscilloscope display and sampling frequency up to 16 K
- Import and export of 30 s data

System Overview

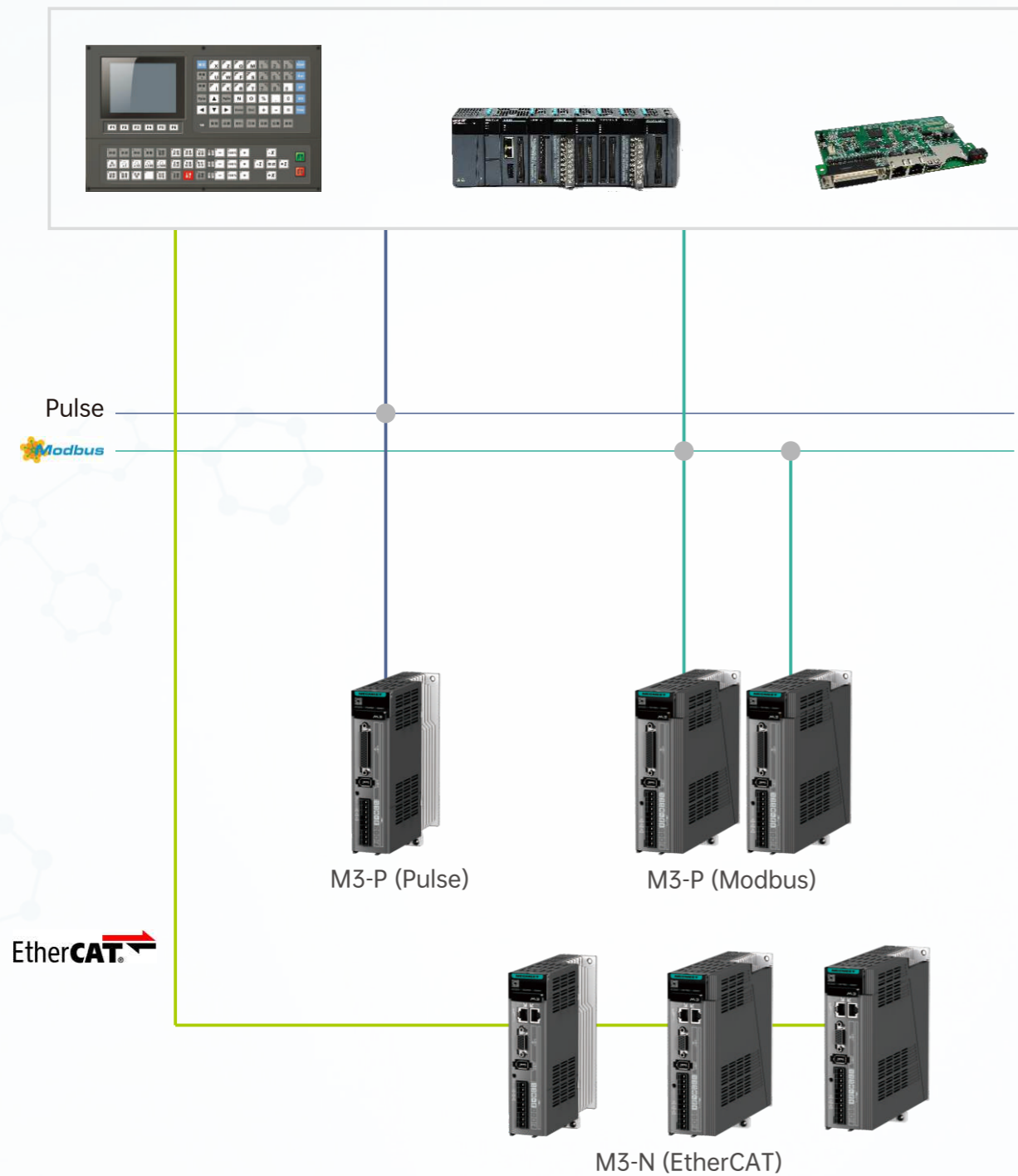

Servo Drive Model

M3 - P S 5R5 A - XX
 1 2 3 4 5 6

1 Product series M3 series servo	3 Voltage level S: 220 V	5 Structural feature A: Standard version
2 Drive type P: Pulse type N: EtherCAT	4 Rated current 1R6: 1.6A 2R8: 2.8A 5R5: 5.5A 7R6: 7.6A	6 Software feature Null: Standard version

Electrical Specifications

Voltage class	220 V			
Model	M3-*S1R6A	M3-*S2R8A	M3-*S5R5A	M3-*S7R6A
Power rating	200 W	400 W	750 W	1 kW
Size	Size A		Size B	
Phase	Single-phase		Single/Three-phase	
Rated input current (A)	2.3	4.0	7.6/3.7	9.6/5.1
Rated output current (A)	1.6	2.8	5.5	7.6
Max. output current (A)	5.8	10.1	16.9	22.0
Main circuit power	200 to 240V, -10% to +10%, 50/60 Hz			
Control circuit power	/			
Braking resistor	No built-in braking resistor			

Servo Motor Model

SPM - S C 8 06 04 M A K - X
 1 2 3 4 5 6 7 8 9 10

1 Product series SPM series	5 Motor frame 04: 40 06: 60 08: 80	7 Inertia M: Medium inertia
2 Voltage class S: 220 V	6 Power Below 100 W: one number and one letter A: Power = Number * 10 Example: 5A = 5 * 10 = 50 W	8 Whether with brake A: Without brake B: With brake
3 Rated speed C: 3000 rpm	100 W to 9.9 kW: two numbers Power = Number * 100 Example: 02 = 2 * 100 = 200 W	9 Definition M: With keyway without oil seal O: Round shaft with oil seal K: With keyway and oil seal
4 Encoder type 8: 17-bit multi-turn absolute magnetic encoder		10 Motor design number

Cable Model

Power cable model

SPL - MA05 - M5 - XX - X
 1 2 3 4 5

1 Product series SPL series	3 Applicable drive M5: M5 series and M3 series
2 Cable type MA05: H series straight plug motor power cable, compatible with 40&60&80 frames BMA05: H series straight plug motor power cable (with brake), compatible with 40&60&80 frames	4 Cable length 03: 3 m 05: 5 m
	5 Flexible cable or not Blank: Normal cable R2: 10 million times flexible cable

Encoder cable model

SPL - E 0 3 - M5 - XX - X
 1 2 3 4 5 6 7

1 Product series SPL series	4 Plug type 3: Straight plug (with battery case) 4: Straight plug (without battery case)	6 Cable length 03: 3 m 05: 5 m
2 Cable type E: Encoder cable	5 Applicable drive M5: M5 series and M3 series	7 Flexible cable or not Blank: Normal cable R2: 10 million times flexible cable
3 Encoder type 0: Absolute encoder		

Servo System Configuration

Motor model	Drive model	Power cable (without brake)	Power cable (with brake)	Encoder cable (with battery)	Encoder cable (without battery)
40/60/80 frame 100 W to 1 kW Vn = 3000 rpm Vmax = 6000/5000/4000 rpm Straight plug standard motors Medium inertia					
SPM-SC*0401M*K-H1	M3-*S1R6A	SPL-MA05-M5-XX	SPL-BMA05-M5-XX	SPL-E03-M5-XX	SPL-E04-M5-XX
SPM-SC*0604M*K-H1	M3-*S2R8A	SPL-MA05-M5-XX	SPL-BMA05-M5-XX	SPL-E03-M5-XX	SPL-E04-M5-XX
SPM-SC*0807M*K-H1	M3-*S5R5A	SPL-MA05-M5-XX	SPL-BMA05-M5-XX	SPL-E03-M5-XX	SPL-E04-M5-XX
SPM-SC*0810M*K-H1	M3-*S7R6A	SPL-MA05-M5-XX	SPL-BMA05-M5-XX	SPL-E03-M5-XX	SPL-E04-M5-XX

Technical Parameters of Motors

Motor model	Rated voltage (V)	Rated power (W)	Rated speed (rpm)	Max. speed (rpm)	Rated torque (N·m)	Peak torque (N·m)	Rated current (A)	Peak current (A)	Rotor inertia (10 ⁻⁴ kg·m ²)
40/60/80 frame 100 W to 1 kW Vn = 3000 rpm Vmax = 6000/5000/4000 rpm Straight plug standard motors Medium inertia									
SPM-SC*0401M*K-H1	220	100	3000	6000	0.32	0.96	1	3	0.06(0.08)
SPM-SC*0604M*K-H1	220	400	3000	5000	1.27	4.5	2.8	9.8	0.68(0.73)
SPM-SC*0807M*K-H1	220	750	3000	5000	2.4	8	4.8	16	1.72(1.77)
SPM-SC*0810M*K-H1	220	1000	3000	4000	3.2	9.6	4.8	14.4	2.4(2.45)

Note: Parameters in parentheses belong to motors with brakes.

M3-P General Specifications

Basic specifications	
Main circuit power supply	200 to 240 V, -10% to +10%, 50/60 Hz
Control mode	IGBT, PWM control, and sine wave current drive mode
Encoder	Absolute encoder
Interface	
Key	5 keys
LED display	Five 8-segment LEDs
Power indicator	CHARGE indicator
IO	
DI (various functions defined by parameters)	8 general inputs, optocoupler isolation, NPN and PNP inputs available Input voltage range 20 to 30 V, input impedance 3.9 K
DO (various functions defined by parameters)	5 general outputs, optocoupler isolation, NPN and PNP outputs available Maximum operating voltage 30 V, maximum current 100 mA
Communication	
RS485	Modbus communication protocol
USB	Connect the computer and the servo drive for commissioning and relevant tuning
General function	
Auto-adjustment	The host computer issues an action command to run the motor, during which the load moment of inertia ratio is estimated in real time and the stiffness level is automatically set
Switchover of multiple control modes	Position mode; Speed mode; Torque mode; Position/Speed mode switchover; Speed/Torque mode switchover; Position/Torque mode switchover
Pulse frequency division	Arbitrary frequency division
Protection function	Overvoltage, undervoltage, overcurrent, overspeed, stall, overheat, overload, encoder abnormality, input phase loss, and excessive position deviation
High-frequency vibration suppression	4 sets of notch filters, suppressing the vibration from 0 to 4000 Hz; 1 set of speed reference notch filter from 0 to 1000 Hz
End vibration suppression	2 sets of filters, suppressing the end low-frequency vibration from 1 Hz to 100 Hz
Homing mode	Multiple homing modes
Reverse clearance compensation	Used to improve the response delay that occurs when the traveling direction of the machine is reversed
Mechanical analyzer	Used to analyze frequency features of the mechanical system through the host computer software
Inertia identification	Offline and online system inertia identification
Torque observer	Load torque observation and compensation
Friction compensation	System friction compensation
Touch probe	Two touch probes
Motor cogging torque compensation	Supported

M3-N General Specifications

Basic specifications	
Main circuit power supply	200 to 240 V, -10% to +10%, 50/60 Hz
Control mode	IGBT, PWM control, and sine wave current drive mode
Encoder	Absolute encoder
Interface	
Key	5 keys
LED display	Five 8-segment LEDs
Power indicator	CHARGE indicator
IO	
DI (various functions defined by parameters)	5 general inputs, optocoupler isolation, NPN and PNP inputs available Input voltage range 20 to 30 V, input impedance 3.9 K
DO (various functions defined by parameters)	3 general outputs, optocoupler isolation, NPN and PNP outputs available Maximum operating voltage 30 V, maximum current 100 mA
Communication	
EtherCAT	CoE and SoE communication protocols, in compliance with CiA402 profile
USB	Connect the computer and the servo drive for commissioning and relevant tuning
General function	
Auto-adjustment	The host computer issues an action command to run the motor, during which the load moment of inertia ratio is estimated in real time and the stiffness level is automatically set
Switchover of multiple control modes	Position mode; Speed mode; Torque mode; Position/Speed mode switchover; Speed/Torque mode switchover; Position/Torque mode switchover; EtherCAT mode
Protection function	Overvoltage, undervoltage, overcurrent, overspeed, stall, overheat, overload, encoder abnormality, input phase loss, and excessive position deviation
High-frequency vibration suppression	4 sets of notch filters, suppressing the vibration from 0 to 4000 Hz; 1 set of speed reference notch filter from 0 to 1000 Hz
End vibration suppression	2 sets of filters, suppressing the end low-frequency vibration from 1 Hz to 100 Hz
Homing mode	Multiple homing modes
Reverse clearance compensation	Used to improve the response delay that occurs when the traveling direction of the machine is reversed
Mechanical analyzer	Used to analyze frequency features of the mechanical system through the host computer software
Inertia identification	Offline and online system inertia identification
Torque observer	Load torque observation and compensation
Friction compensation	System friction compensation
Touch probe function	Two touch probes
Motor cogging torque compensation	Supported

M3-N Communication Specifications

Communication standard	
IEC 61158 Type12, IEC 61800-7 CiA402 Drive Profile (CoE)	
Physical layer	
Transmission protocol	100 BASE-TX (IEEE 802.3)
Transmission distance	Less than 100 m between two nodes
Interface	CN3 (RJ45): EtherCAT Signal IN CN4 (RJ45): EtherCAT Signal OUT
Cable	Category 5 twisted pair
Application layer	
SDO	SDO request, SDO response
PDO	Mutable PDO mapping
CiA402 Drive Profile	Profile Position Mode
	Profile Velocity Mode
	Profile Torque Mode
	Homing Mode
	Cyclic Synchronous Position Mode
	Cyclic Synchronous Velocity Mode
Cyclic Synchronous Torque Mode	
Sync mode	
Distributed Clock (DC) mode	

Network Synchronization

- The EtherCAT network selects the first slave clock as the reference clock, and the clocks of all other devices (including master and slave) are synchronized with this reference clock.
- Through the synchronization signal (SYNC), all EtherCAT devices can use the same system clock to control the synchronous task execution of each device, and realize the synchronization of local tasks of each device with the reference clock.
- The system can achieve a jitter of 20 ns and a synchronization error of 15 ns, even though 300 nodes are between two devices with the cable length up to 120 m.

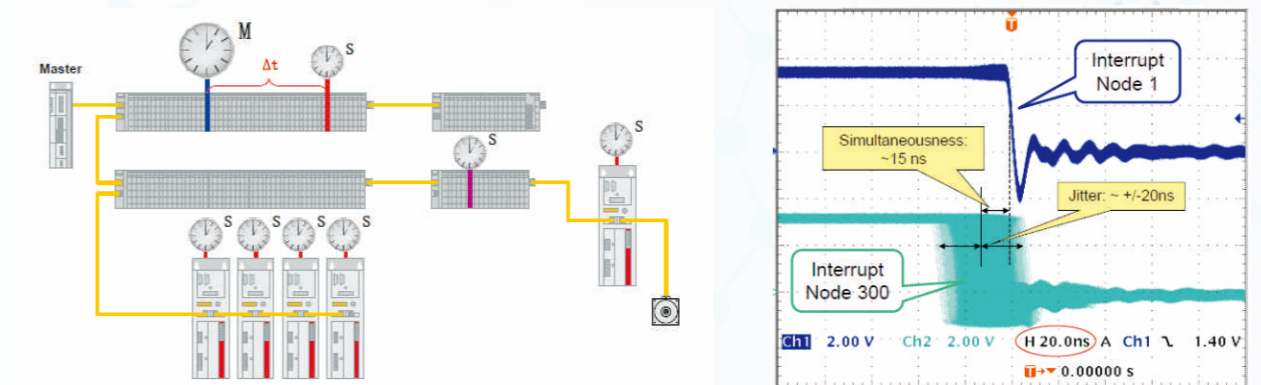

M3-P Drive Wiring

Size A models connected to peripheral devices

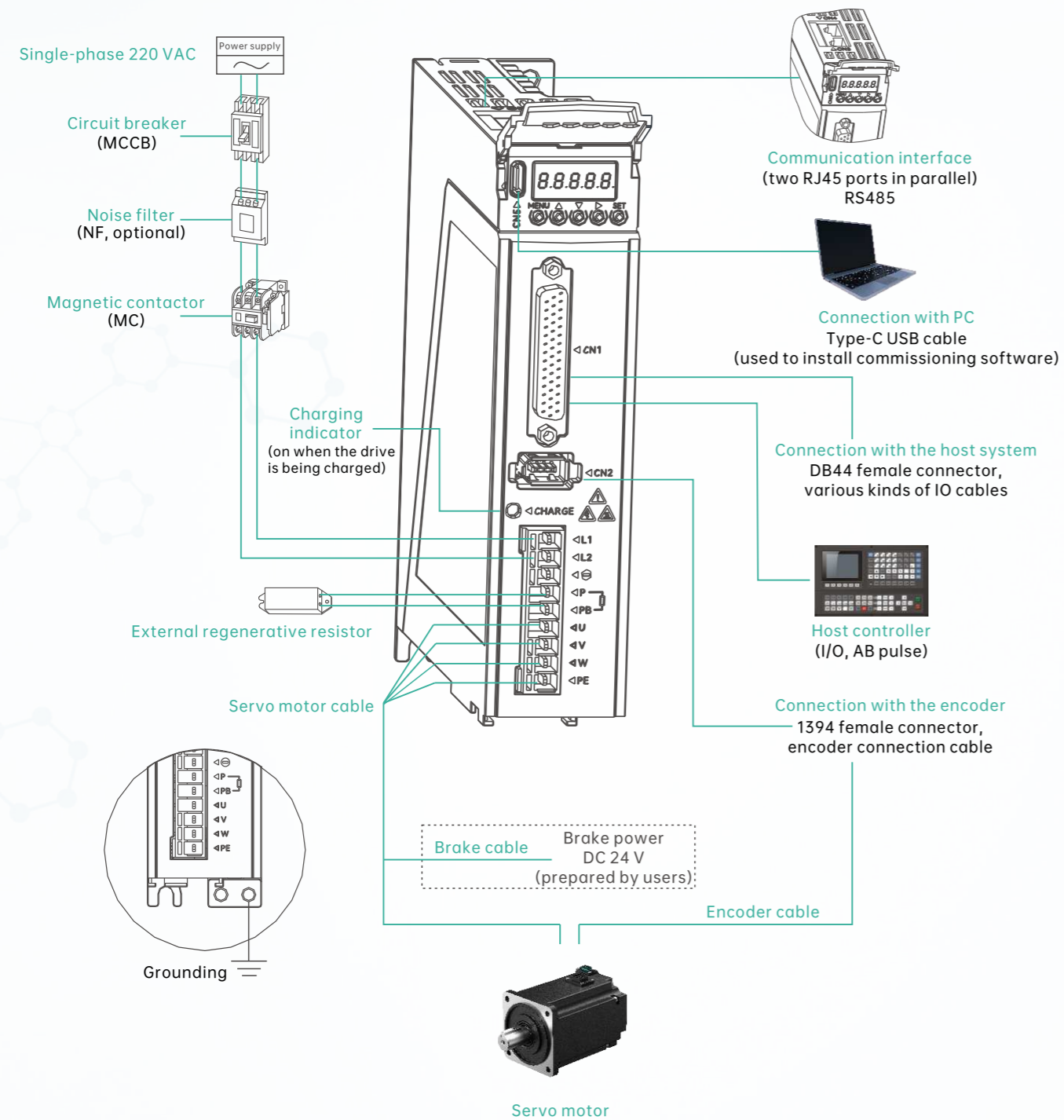

Size B models connected to peripheral devices

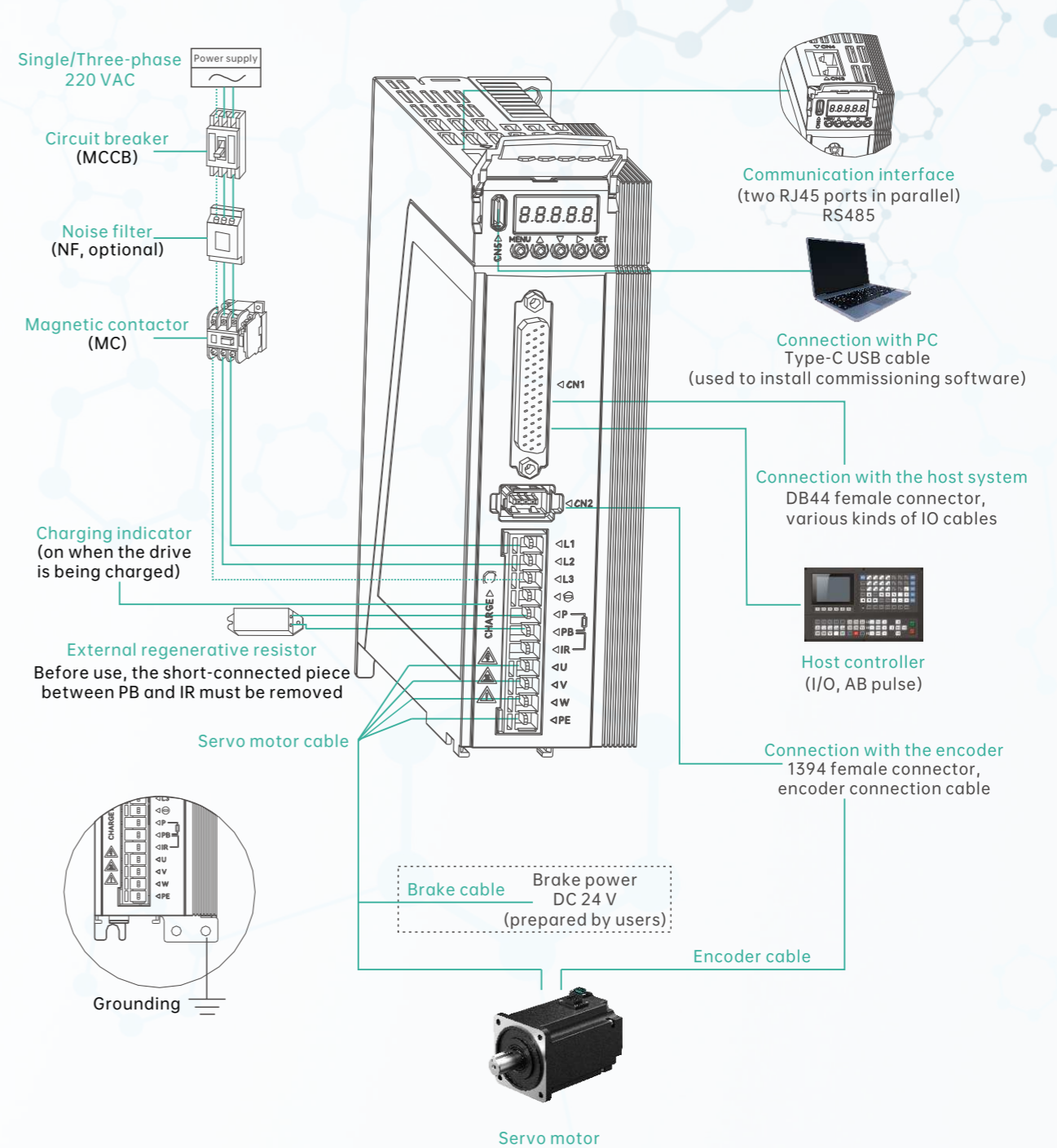

M3-N Drive Wiring

Size A models connected to peripheral devices

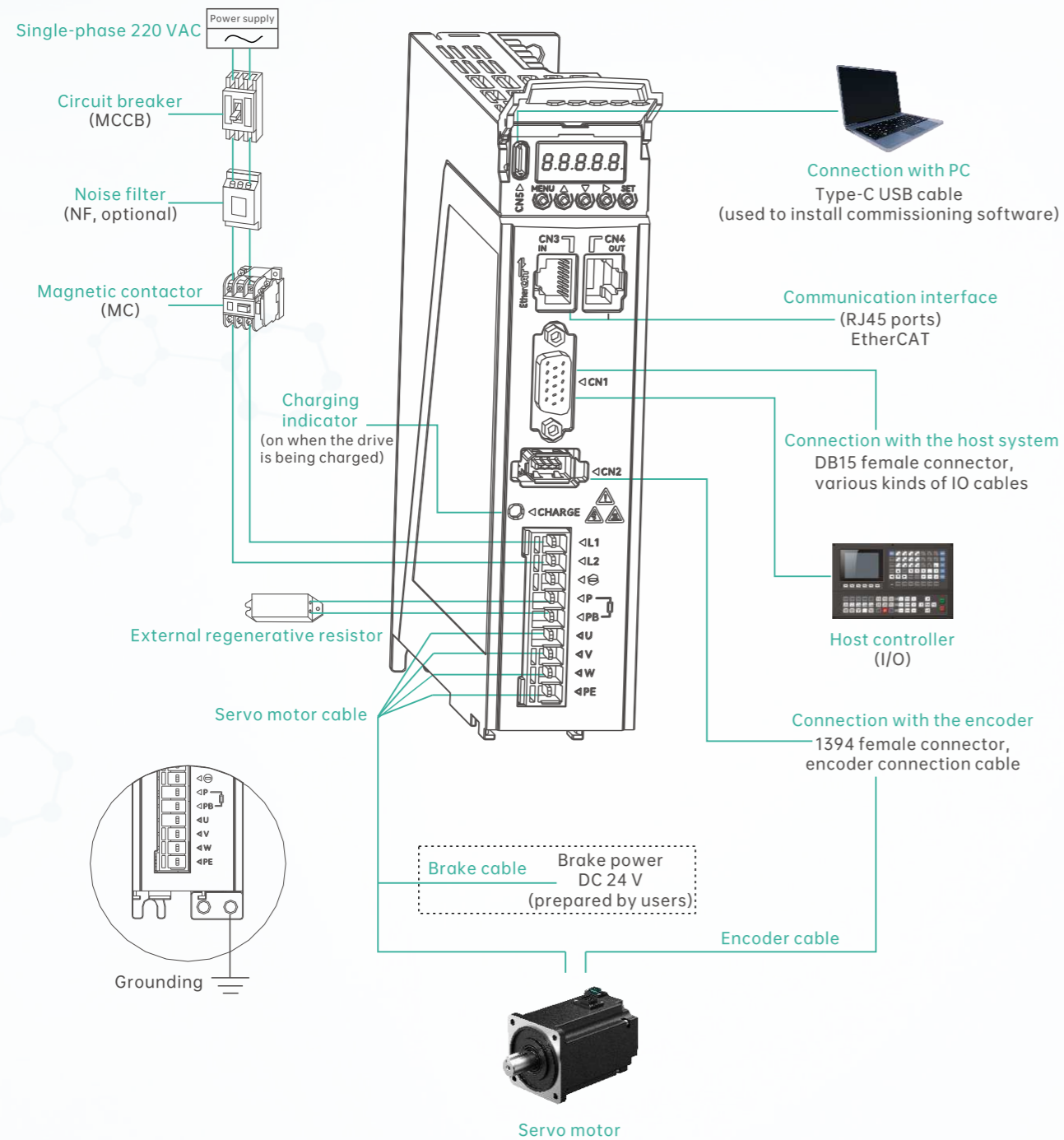

Size B models connected to peripheral devices

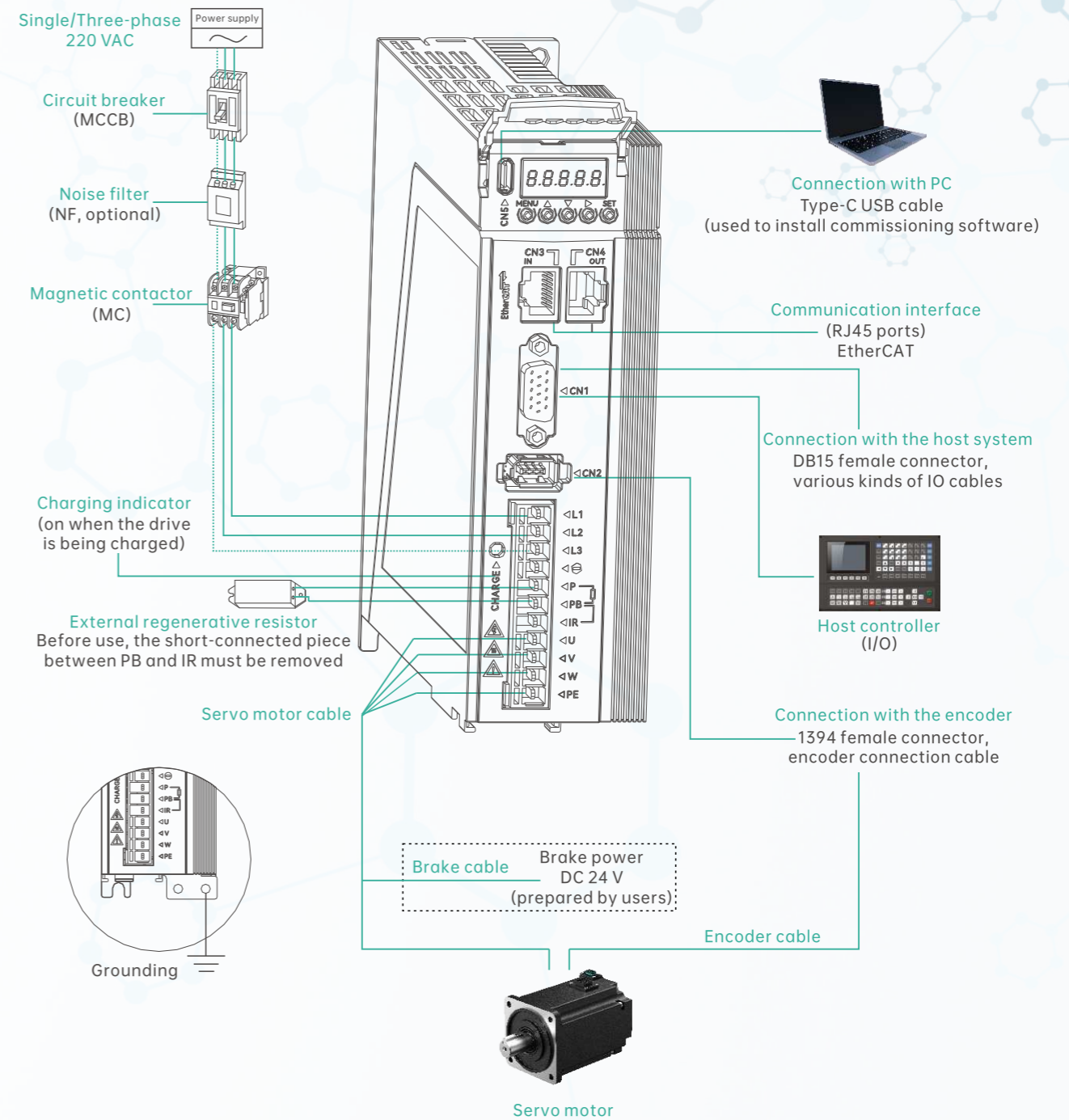

Servo Motor Dimensions

40 frame, medium inertia

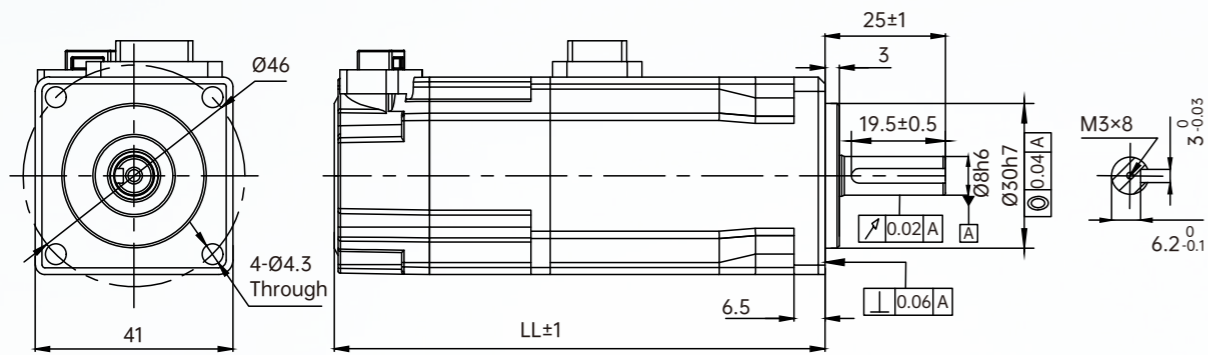

Model	L(mm)
SPM-SC*0401M*K-H1	81.5(101.5)

Note: Dimensions in parentheses are dimensions for motors with brakes.

80 frame, medium inertia

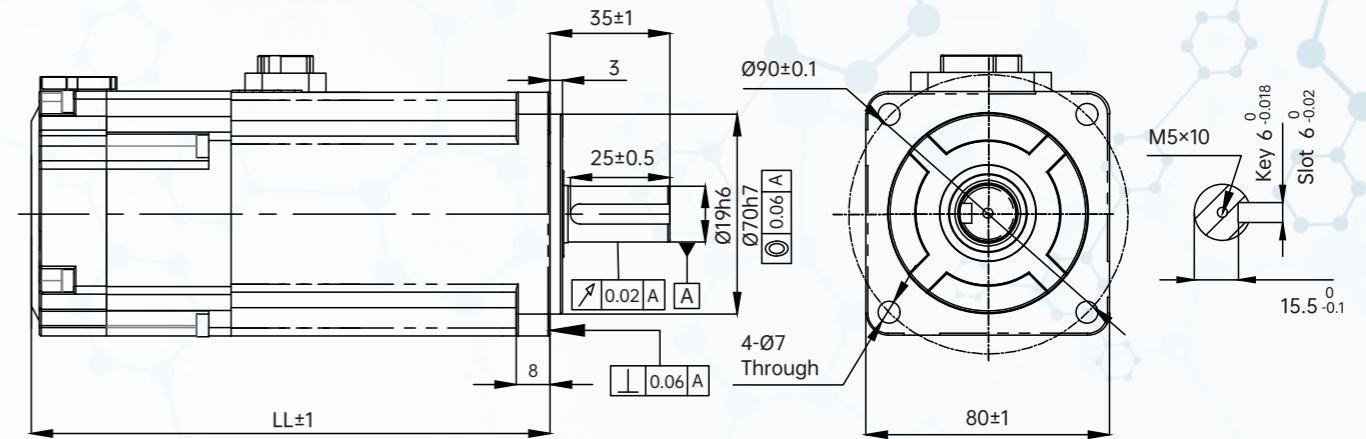

Model	L(mm)
SPM-SC*0807M*K-H1	106(140)
SPM-SC*0810M*K-H1	120(154)

Note: Dimensions in parentheses are dimensions for motors with brakes.

60 frame, medium inertia

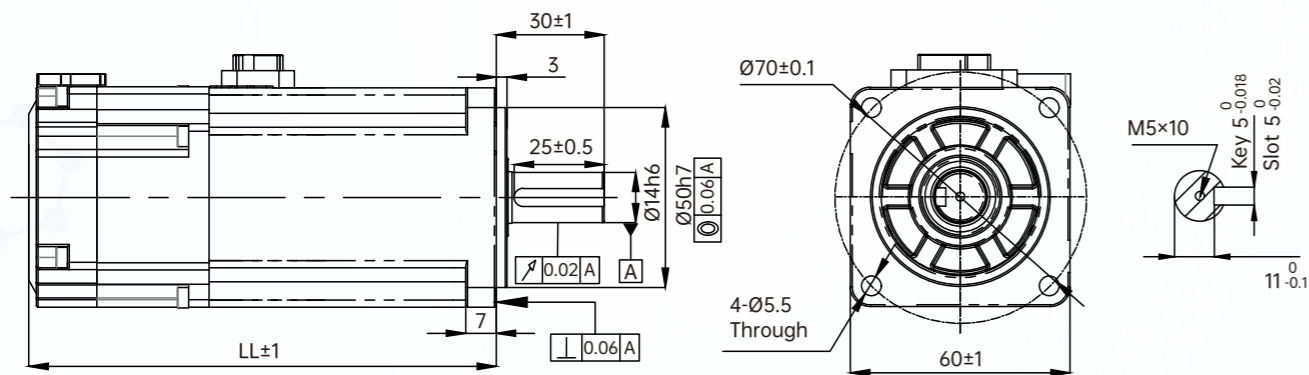

Model	L(mm)
SPM-SC*0604M*K-H1	96(123)

Note: Dimensions in parentheses are dimensions for motors with brakes.

M3-P Dimensions

Size A

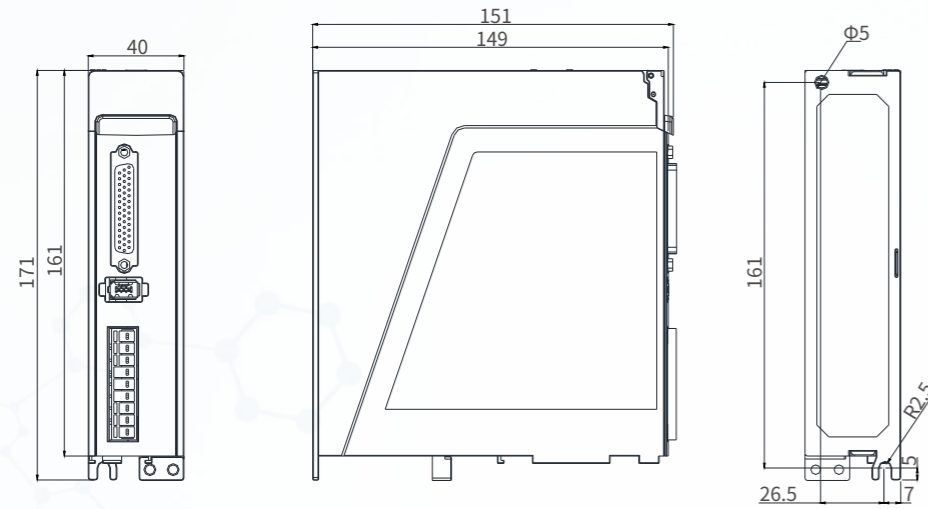

Size B

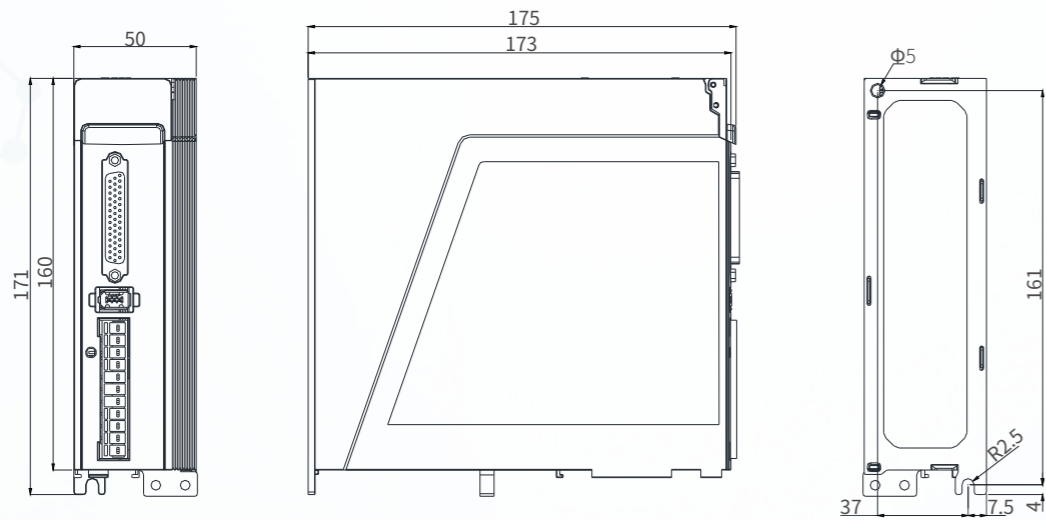

M3-N Dimensions

Size A

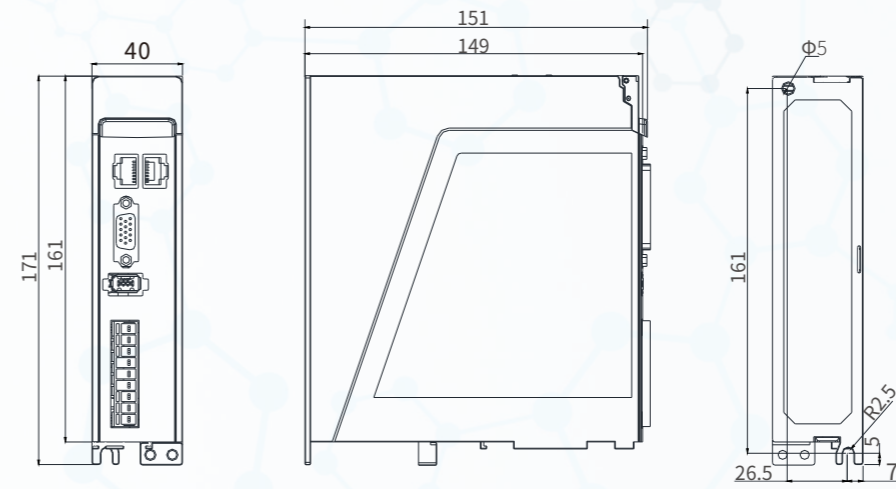

Size B

