

Power Solutions

- Telecom Power
- Server Power
- Electric Power
- Medical Power
- Display Power
- LED Power
- Laser Power
- OA Power
- Flat Panel Power
- Bi-directional Inverters for Portable Power
- Solar & BESS & EV Charging Solution

Industrial Automation

- Servo System
- Control System
- Elevator Controller
- Linear Motors
- IoT Solution
- Encoder
- Variable Frequency Drive
- Internal Gear Pump

eMobility & EV Infrastructure

- Integrated Charging System (OBC & DC-DC)
- E-Compressor
- TV EDU
- Inverter
- Intelligent Active Hydraulic Suspension (i-AHS)
- Thermal Mgmt. System
- Power Electronic Unit (2-in-1, 3-in-1)
- Construction Machinery Controller
- Railway A/C Controller
- Railway VFD
- Light Electric Vehicle Motors, Inverters, and Charging System

Intelligent Equipment

- Intelligent Welding
- Industrial Microwave
- Automatic Car Washing Machine
- Electric Submersible-Progressing Cavity Pump
- Polysilicon Water Quenching Equipment
- Intelligent Lifting Devices

Home Appliance Control Solutions

- Residential A/C Controller
- Vehicle A/C Controller
- Refrigerator Controller
- Industrial Microwave
- Commercial A/C Controller
- Solar A/C Controller
- Washer/Dryer Controller
- Smart Bidet
- Heat Pump Controller
- Mini Compressor Controller
- Residential Microwave
- RF Thawing System

Precision Connection

- FFC
- FPC
- Coaxial Cable
- CCS
- Litz Wire
- Peek Wire

SHENZHEN MEGMEET ELECTRICAL CO., LTD.

Add 1: 5th Floor, Block B, Unisplendour Information Harbor, Langshan Rd., Science & Technology Park, Nanshan District, Shenzhen, 518057, China

Add 2: 34th Floor, High-tech Zone Union Tower, No.63 Xuefu Road, Nanshan District, Shenzhen, 518057, China

FOLLOW US

Q Megmeet



Version: 202603

Megmeet reserves the right to modify the technical parameters and appearance of the products in this catalogue without prior advice to the users.

M6 Series Servo System



ABOUT MEGMEET

MEGMEET is a comprehensive solution provider for hardware and software R&D, production, sales, and service in the field of electrical automation. With power electronics and automation control at its core, MEGMEET's main businesses include Power Solutions, Industrial Automation, emobility & EV Infrastructure, Intelligent Equipment, Home Appliance Control Solutions, and Precision Connection.

MEGMEET has established a robust R&D, manufacturing, marketing, and service platform, with over 13,000 employees, including more than 3,000 R&D staff worldwide. MEGMEET's global presence includes R&D Centers in China, the United States, and Germany; Manufacturing Centers in Thailand, India, the United States, and China; and Regional Offices across North America, South America, Europe, Central Asia, Northeast Asia, Southeast Asia, India, the Middle East, Oceania, and Africa.

MEGMEET is committed to creating a cleaner living environment for all human beings through more efficient energy utilization and improved manufacturing efficiency. MEGMEET aims to become the world leader in electrical automation and achieve the goal of MEGMEET EVERYWHERE.

 **3000+**
R&D Staff

 **10**
R&D Centers

 **9**
Manufacturing Bases

 **13000+**
Total Employees

 **1990+**
No. of Patents & IP Rights

R&D CAPABILITY

Sustainable R&D Investment

R&D Investment

R&D Employees
>3000 

Percentage against Total Employees
23% 

Percentage against Total Sales
>12% 

Patents & Industry Standards

No. of Patents & IP Rights
1990+
↑ 400+ new in 2024

National & International standards
32
● 9 lead author

Industry Standards Drafted
38
● 28 lead author

R&D Investment (in Millions of USD)

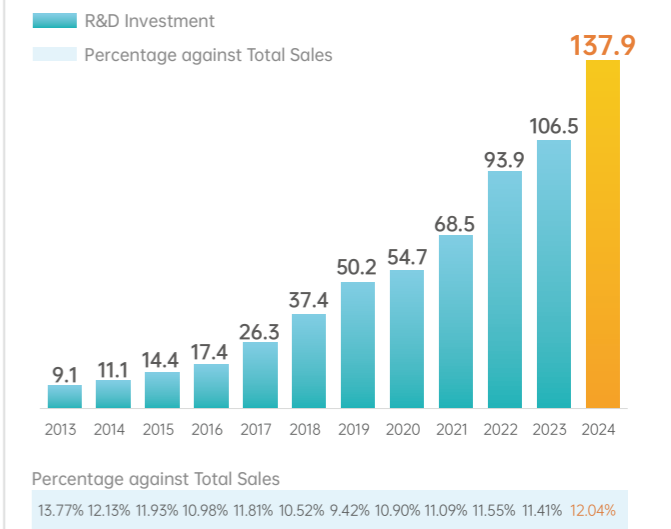

Testing Capabilities & Management System



MEGMEET's testing capabilities and management system have been certified by CNAS, TÜV, UL-WTDP, and UL-CTF. MEGMEET's test results are recognized globally.



Introduction

Megmeet's new-generation M6 series servo system is featured with high response, high precision and high synchronization, and equipped with advanced functions such as online inertia identification, gain auto-tuning, vibration suppression, and quadrant compensation. Together with the intelligent Megmeet host controller, M6 is able to meet market requirements for mechanical equipment by high precision, high stability, high efficiency and ease of use.

High response

- Increase from 1.0 kHz to 2.6 kHz
- High current loop and speed loop refresh frequency
- Faster response to commands
- High rigidity

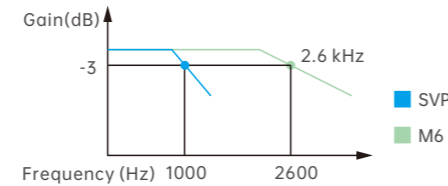

High overload

- 3 times overload capacity

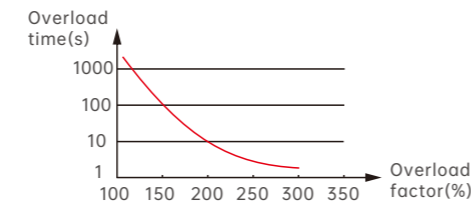

High bandwidth

- Input and output pulse up to 4 Mpps
- Supports differential and open-collector input
- Three pulse modes: A/B orthogonal, direction + pulse and CW/CCW

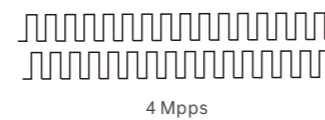

Multiple series motors

- High, medium and low inertia motors, select the appropriate inertia to obtain the best inertia ratio
- Different speed motors meet the operation requirements of different equipment
- High-inertia motors are used in occasions where speed stability is required, and have strong resistance to external load impacts, such as machine tools.
- Low inertia motors are used for fast response occasions, high-speed positioning and reciprocating motion, such as electronic equipment

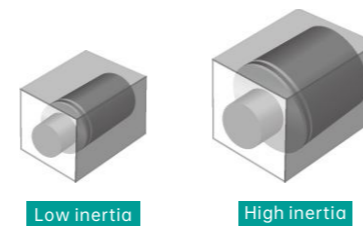

Integrated interface for encoders

23-bit multi-turn absolute encoder

- High resolution, 8388608 p/r, 65535 turns of absolute position for maximum record
- The low-speed torque is more stable and the positioning is more accurate
- The motor still remains in its position after the servo unit is powered off

Incremental encoder

- Economical, easy wiring
- Accurate angle identification

Sin/Cos encoder

- Internal 16-bit A/D subdivision
- Improved positioning accuracy and low-speed stability

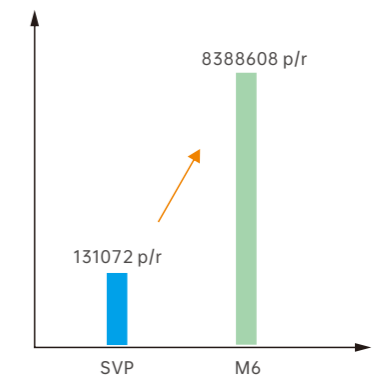

Fully closed-loop control

Fully closed-loop control to reduce control errors caused by defects such as mechanical clearance and elasticity and improve control accuracy and system rigidity

- ABZ incremental encoder
- BiSS-C encoder
- SSI encoder
- Sin/Cos encoder

Fully closed-loop control with the local encoder

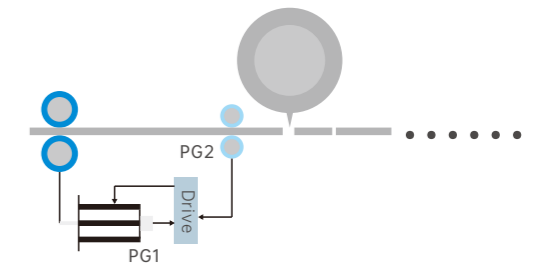

Important Functions

Inertia identification

Both offline and online inertia identification can be performed. Through inertia identification, the load inertia ratio can be accurately obtained, which is helpful to complete the commissioning quickly and achieve the best control effect.

Gain adjustment

- Automatic gain adjustment: By selecting the rigidity level, matching gain parameters are automatically generated to meet the requirements of rapidity and stability.
- Manual gain adjustment: Manually fine-tune the gain to optimize the control effect.
- Speed feedforward: The function is used in the position control mode to reduce position following errors.
- Torque feedforward: In the position control mode, it can reduce the position deviation during acceleration and deceleration; and in the speed control mode, it can reduce the speed deviation when the speed is fixed.
- Multiple gain switchover modes

Torque disturbance observation

In a non-torque control mode, by detecting and estimating the external disturbance torque received by the system, the torque reference can be compensated to reduce the influence of external disturbance on the servo so as to reduce vibration.

High-frequency mechanical resonance suppression

Automatically search for high-frequency mechanical resonance frequency points, and reduce the gain at a specific frequency through 4 sets of traps, which can suppress mechanical resonance.

Low-frequency mechanical resonance suppression

For long-end mechanical loads, the low-frequency resonance suppression function can effectively reduce the end jitter caused by positioning completion or emergency stop.

Friction compensation

For loads with high friction, such as drive shafts of belts, friction compensation can shorten positioning time and reduce machining errors caused by friction.

Quadrant compensation

In the application of arc trajectory interpolation with more than 2 axes, quadrant compensation can reduce the arc distortion caused by friction non-linearity (the trajectory protrusion at the alternation of the four quadrants), and increase the accuracy of servo system control and the uniformity of motion.

M6-N Communication Specifications

Communication standard	
IEC 61158 Type12, IEC 61800-7 CiA402 Drive Profile (CoE)	
Physical layer	
Transmission protocol	100 BASE-TX (IEEE 802.3)
Transmission distance	Less than 100 m between two nodes
Interface	CN4 (RJ45): EtherCAT Signal IN CN5 (RJ45): EtherCAT Signal OUT
Cable	Category 5 twisted pair
Application layer	
SDO	SDO request, SDO response
PDO	Mutable PDO mapping Profile Position Mode Profile Velocity Mode
CiA402 Drive Profile	Homing Mode Interpolated Position Mode Cyclic Synchronous Position Mode Cyclic Synchronous Velocity Mode
Sync mode	
Distributed clock (DC) mode	

Network Synchronization

- The EtherCAT network selects the first slave clock as the reference clock, and the clocks of all other devices (including master and slave) are synchronized with this reference clock.
- Through the synchronization signal (SYNC), all EtherCAT devices can use the same system clock to control the synchronous task execution of each device, and realize the synchronization of local tasks of each device with the reference clock.
- The system can achieve a jitter of 20 ns and a synchronization error of 15 ns, even though 300 nodes are between two devices with the cable length up to 120 m.

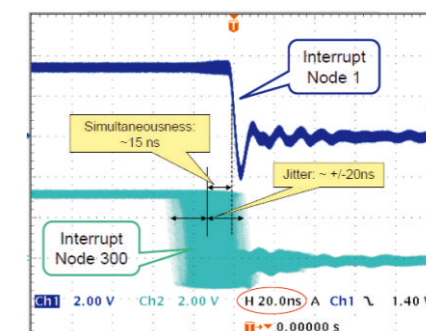
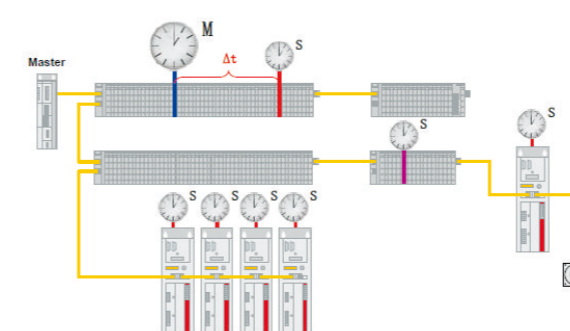

Specifications

Basic specification			
Main circuit power supply	200 to 240 V, -10% to +10%, 50/60 HZ or 380 to 480 V, -15% to +10%, 50/60 HZ		
Control circuit power supply	Single-phase 200 to 240 V, -15% to +10%, 50/60 HZ		
Control mode	IGBT, PWM control, and sine wave current drive mode		
Encoder	Rotating motor: Absolute encoder Incremental encoder Sin/Cos encoder	Linear motor: Absolute encoder Incremental encoder Sin/Cos encoder	Second encoder: Incremental encoder BiSS-C encoder SSI encoder Sin/Cos encoder
Interface			
Button	5 buttons		
LED display	Five 8-segment LEDs		
Power indicator	CHARGE indicator		
STO function	General safety STO function, optional		
Fully closed-loop interface	Fully closed-loop function, optional		
Expansion card interface	Extensible motion control card, optional		
IO			
DI (various functions defined by parameters)	10 general inputs, optocoupler isolation, NPN and PNP inputs available Input voltage range 20 to 30 V, input impedance 3.9 K		
DO (various functions defined by parameters)	6 general outputs, optocoupler isolation, NPN and PNP outputs available Maximum operating voltage 30 V, maximum current 100 mA		
AI (functions configured according to modes)	2 analog inputs, +/-10 V, 16 bits for AI1, 12 bits for AI2 Input impedance: AI1 impedance 12 K, AI2 impedance 17 K Signal delay: AI1 delay 70 uS, AI2 delay 80 uS		
Communication function			
RS485	Modbus communication protocol, only for the M6-P series		
CAN	CANopen communication protocol, in compliance with CiA402 profile, only for the M6-P series		
EtherCAT	CoE and SoE communication protocols, in compliance with CiA402 profile, only for the M6-N series		
MECHATROLINK-III	MECHATROLINK-III bus protocol, only for the M6-M series		
PROFINET	PROFINET bus communication protocol, PROFINET profile integrated, only for the M6-F series		
USB	Connect the computer and the servo drive for commissioning and relevant tuning		
General function			
Auto-adjustment	The host computer issues an action command to run the motor, during which the load moment of inertia ratio is estimated in real time and the rigidity level is automatically set		
Switchover of multiple control modes	Position mode; Speed mode; Torque mode; Position/Speed mode switchover; Speed/Torque mode switchover; Position/Torque mode switchover; Fully closed-loop control; CANopen mode; EtherCAT mode		
Pulse frequency division	Arbitrary frequency division		
Protection function	Overvoltage, undervoltage, overcurrent, overspeed, stall, overheat, overload, encoder abnormality, input phase loss, output phase loss, excessive position deviation		

General function	
High-frequency vibration suppression	4 sets of notch filters, suppressing the vibration from 0 to 4000 Hz; 1 set of speed reference notch filter from 0 to 1000 Hz
End vibration suppression	2 sets of filters, suppressing the end low-frequency vibration from 1 Hz to 100Hz
Homing mode	Multiple homing modes
Gantry control	Gantry synchronization function
Reverse clearance compensation	Used to improve the response delay that occurs when the traveling direction of the machine is reversed
Mechanical analyzer	Used to analyze frequency features of the mechanical system through the host computer software
Inertia identification	Offline and online system inertia identification
Torque observer	Load torque observation and compensation
Electronic cam	512 points electronic cam curve
Friction compensation	System friction compensation

Host Computer Software

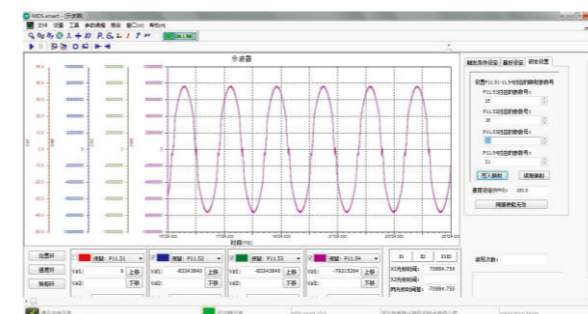
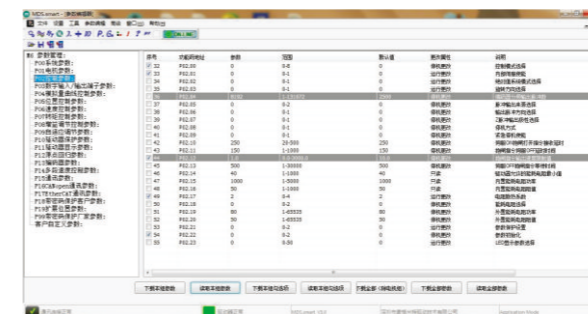

- Parameter auto-tuning
- Friendly HMI
- Shared USB port for firmware upgrade and host computer communication
- Real-time online data monitoring with 32 bit * 4-channel real-time oscilloscope display and sampling frequency up to 16 K
- Input and output of 30 s data

Servo Drive Model

M6 – P S 5R5 A X – SE
 1 2 3 4 5 6 7

<p>1 Product series</p> <p>M6: M6 series servo</p>	<p>2 Drive type</p> <p>P: General type N: EtherCAT M: MECHATROLINK-III F: PROFINET</p>	<p>3 Voltage class</p> <p>S: 220 V T: 380 V</p>
<p>4 Rated current</p> <p>220 V</p> <p>1R6: 1.6 A 2R8: 2.8 A 5R5: 5.5 A 7R6: 7.6 A 012: 11.6 A</p> <p>380 V</p> <p>3R5: 3.5 A 5R4: 5.4 A 8R4: 8.4 A 012: 11.9 A 017: 16.5 A 021: 21 A 026: 26 A</p>	<p>5 Hardware version</p> <p>A: Standard version B: Small size version</p>	<p>6 Software version</p> <p>7 Non-standard type</p> <p>SE: SOE version DCL: Double closed-loop</p>

Servo Motor Model

SPM – T C 6 06 02 M A K – X
 1 2 3 4 5 6 7 8 9 10

<p>1 Product series</p> <p>SPM: SPM series</p>	<p>2 Voltage class</p> <p>S: 220 V T: 380 V</p>	<p>3 Speed</p> <p>A: 1000 rpm C: 3000 rpm D: 1500 rpm F: 4000 rpm E: 2000 rpm G: 5000 rpm B: 2500 rpm</p>
<p>4 Encoder type</p> <p>1: Full-line 2500 line incremental encoder 6: 23-bit multi-turn absolute optical encoder 8: 17-bit multi-turn absolute magnetic encoder</p>	<p>5 Frame number</p> <p>04: 40 06: 60 08: 80 13: 130 18: 180</p>	<p>6 Power</p> <p>5A: 50 W 26: 2600 W 01: 100 W 29: 2900 W 02: 200 W 36: 3600 W 04: 400 W 44: 4400 W 07: 750 W 45: 4500 W 10: 1000 W 55: 5500 W 11: 1100 W 75: 7500 W 17: 1700 W</p>
<p>7 Inertia</p> <p>M: Medium inertia (five pairs of poles)</p> <p>8 Whether with brake</p> <p>A: No B: Yes</p>	<p>9 Definition</p> <p>M: With keyway without oil seal O: Round shaft with oil seal K: With keyway and oil seal D: D-type shaft with oil seal T: Non-standard shaft</p>	<p>10 Motor design number</p>

Servo Drive Electrical Specifications

Voltage	Model	SIZE	Phase	Rated input current (A)	Rated output current (A)	Max. output current (A)	Braking resistor
220 V	M6-*S1R6AX	SIZE A	Single-phase	2.2	1.6	5.8	No built-in braking resistor
	M6-*S2R8AX			4	2.8	9.3	
	M6-*S5R5AX		Single/three-phase	7.6/4.2	5.5	16.9	
	M6-*S7R6BX	SIZE B	Three-phase	5.1	7.6	17	Built-in braking resistor
	M6-*S7R6AX			5.1	7.6	22	
	M6-*S012AX			8	11.6	28	
380 V	M6-*T3R5AX	SIZE B	Three-phase	2.4	3.5	8.5	Built-in braking resistor
	M6-*T5R4AX			3.6	5.4	14	
	M6-*T8R4AX			5.5	8.4	22	
	M6-*T012AX			8	11.9	28	
	M6-*T017AX	SIZE C		12	16.5	42	No built-in braking resistor
	M6-*T021AX			16	21	55	
	M6-*T026AX			21	26	65	

System Overview

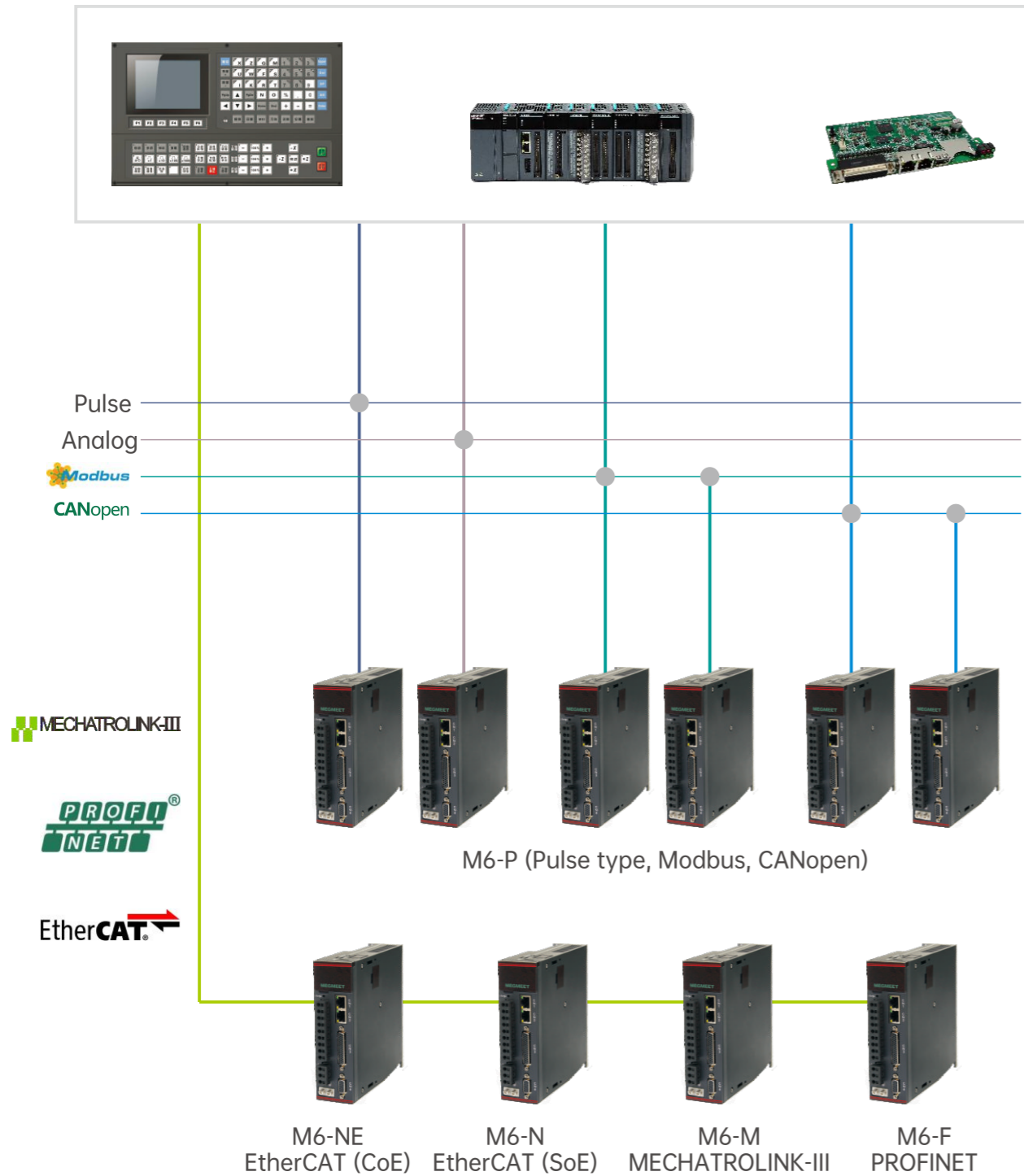

M6 Outline and Mounting Dimensions

SIZE A

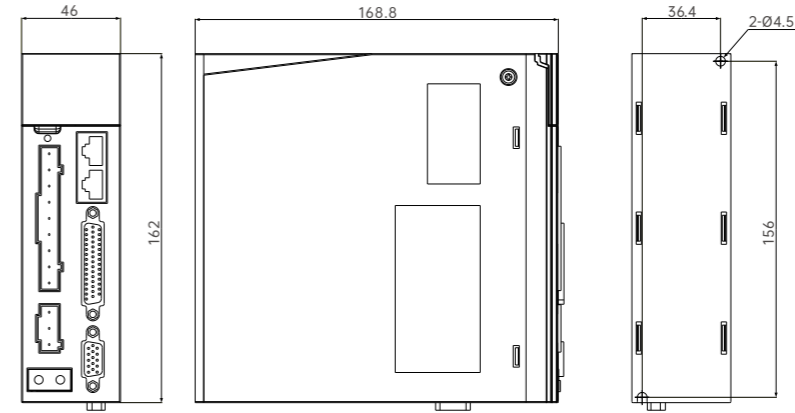

SIZE B

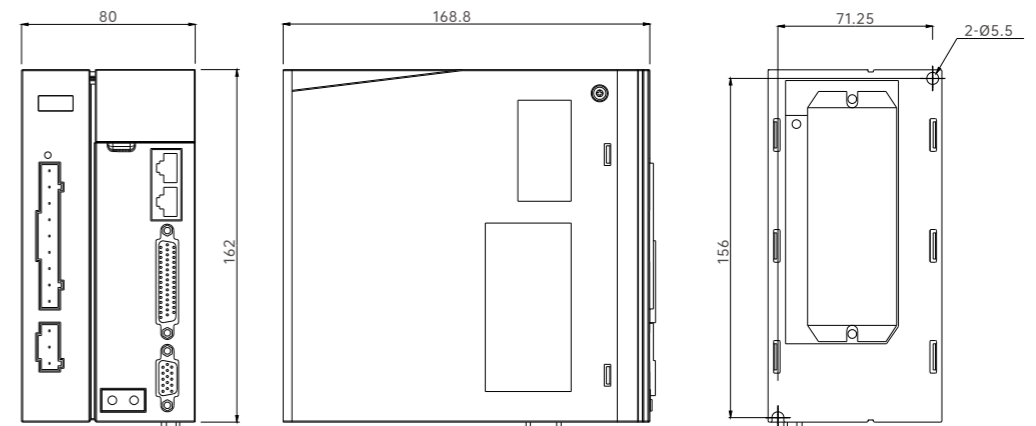

SIZE C

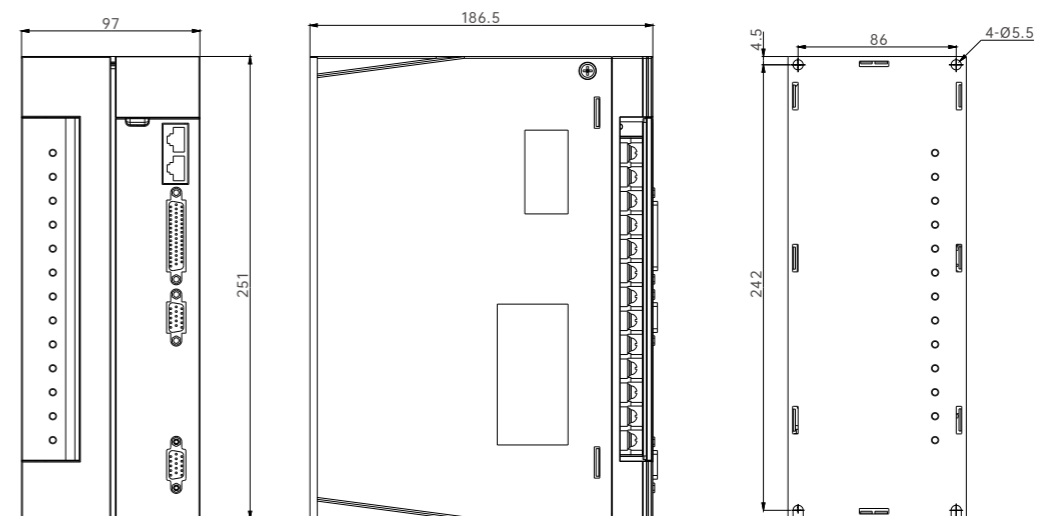

System Configuration Table - Medium Inertia Motor

Voltage	Rated speed (rpm)	Max. speed (rpm)	Power (W)	Motor model	Rated torque (N·m)	Motor frame	Matched drive model	Drive SIZE
220V	3000	6000	50	SPM-SC6045AM**-L	0.16	40	M6-*S1R6AX	A
	3000	6000	50	SPM-SC8045AM**-L	0.16	40	M6-*S1R6AX	A
	3000	6000	100	SPM-SC60401M**-L	0.32	40	M6-*S1R6AX	A
	3000	6000	100	SPM-SC80401M**-L	0.32	40	M6-*S1R6AX	A
	3000	6500	200	SPM-SC60602M**-L	0.64	60	M6-*S1R6AX	A
	3000	6500	200	SPM-SC80602M**-L	0.64	60	M6-*S1R6AX	A
	3000	5000	400	SPM-SC60604M**-L	1.27	60	M6-*S2R8AX	A
	3000	5000	400	SPM-SC80604M**-L	1.27	60	M6-*S2R8AX	A
	3000	5000	750	SPM-SC60807M**-L	2.39	80	M6-*S5R5AX	A
	3000	5000	750	SPM-SC80807M**-L	2.39	80	M6-*S5R5AX	A
	3000	5000	1000	SPM-SC60810M**-L	3.19	80	M6-*S7R6BX	A
	3000	5000	1000	SPM-SC80810M**-L	3.19	80	M6-*S7R6BX	A
	3000	5000	1700	SPM-SC61317M**-W	5.399	130	M6-*S012AX	B
	2000	4000	1100	SPM-SE61311M**-W	5.39	130	M6-*S7R6AX	B
	2000	4000	1700	SPM-SE61317M**-W	8.34	130	M6-*S012AX	B

Voltage	Rated speed (rpm)	Max. speed (rpm)	Power (W)	Motor model	Rated torque (N·m)	Motor frame	Matched drive model	Drive SIZE
380V	2000	4000	1100	SPM-TE61311M**-W	5.39	130	M6-*T5R4AX	B
	2000	4000	1700	SPM-TE61317M**-W	8.34	130	M6-*T8R4AX	B
	2000	4000	2400	SPM-TE61324M**-W	9.5	130	M6-*T017AX	C
	2000	4000	3000	SPM-TE61330M**-W	14.3	130	M6-*T017AX	C
	3000	5000	1700	SPM-TC61317M**-W	5.399	130	M6-*T8R4AX	B
	3000	5000	2600	SPM-TC61326M**-W	8.34	130	M6-*T012AX	B
	3000	5000	3600	SPM-TC61336M**-W	11.5	130	M6-*T012AX	B
	3000	5000	4500	SPM-TC61345M**-W	14.3	130	M6-*T017AX	C
	1500	3000	2900	SPM-TD11829M**-P	18.6	180	M6-*T012AX	B
	1500	3000	2900	SPM-TD61829M**-P	18.6	180	M6-*T012AX	B
	1500	3000	4400	SPM-TD11844M**-P	28.4	180	M6-*T017AX	C
	1500	3000	4400	SPM-TD61844M**-P	28.4	180	M6-*T017AX	C
	1500	3000	5500	SPM-TD11855M**-P	35	180	M6-*T021AX	C
	1500	3000	5500	SPM-TD61855M**-P	35	180	M6-*T021AX	C
	1500	3000	7500	SPM-TD11875M**-P	48	180	M6-*T026AX	C
1500	3000	7500	SPM-TD61875M**-P	48	180	M6-*T026AX	C	

Overview of Servo Motors 40/60/80 medium inertia motors

Motor model	Rated voltage (V)	Rated power (W)	Rated speed (rpm)	Max. speed (rpm)	Rated torque (N·m)	Peak torque (N·m)	Rated current (A)	Peak current (A)	Rotor inertia (10 ⁻⁴ kg·m ²)
SPM-SC6045AM**-L	220	50	3000	6000	0.16	0.48	0.93	2.88	0.036(0.046)
SPM-SC8045AM**-L	220	50	3000	6000	0.16	0.48	0.93	2.88	0.036(0.046)
SPM-SC60401M**-L	220	100	3000	6000	0.32	0.95	0.92	2.85	0.062(0.072)
SPM-SC80401M**-L	220	100	3000	6000	0.32	0.95	0.92	2.85	0.062(0.072)
SPM-SC60602M**-L	220	200	3000	6500	0.64	1.91	1.5	4.66	0.28(0.3)
SPM-SC80602M**-L	220	200	3000	6500	0.64	1.91	1.5	4.66	0.28(0.3)
SPM-SC60604M**-L	220	400	3000	5000	1.27	3.81	2.1	6.5	0.56(0.58)
SPM-SC80604M**-L	220	400	3000	5000	1.27	3.81	2.1	6.5	0.56(0.58)
SPM-SC60807M**-L	220	750	3000	5000	2.39	7.17	4.1	13.4	1.5(1.65)
SPM-SC80807M**-L	220	750	3000	5000	2.39	7.17	4.1	13.4	1.5(1.65)
SPM-SC60810M**-L	220	1000	3000	5000	3.19	9.56	5.7	17.7	2(2.15)
SPM-SC80810M**-L	220	1000	3000	5000	3.19	9.56	5.7	17.7	2(2.15)

Note: The parameters in "()" belong to motors with brakes.

40 frame medium inertia motors

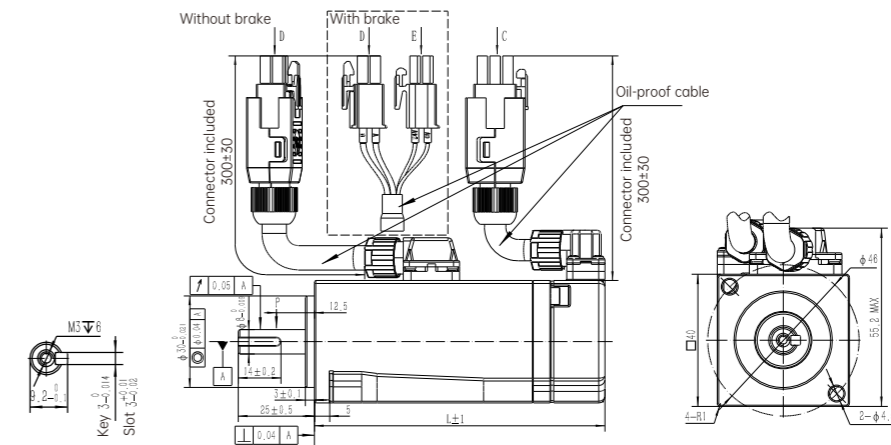

Model	L (mm)
SPM-SC6045AM**-L	56(84)
SPM-SC8045AM**-L	56(84)
SPM-SC60401M**-L	67.7(95)
SPM-SC80401M**-L	67.7(95)

Note: The parameters in "()" belong to motors with brakes.

60 frame medium inertia motors

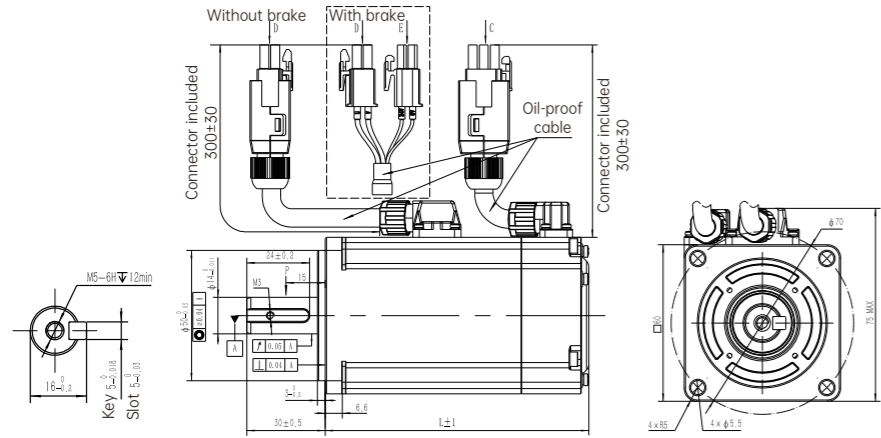

Model	L (mm)
SPM-SC60602M**-L	71.8(101.2)
SPM-SC80602M**-L	71.8(101.2)
SPM-SC60604M**-L	88.8(118.2)
SPM-SC80604M**-L	88.8(118.2)

Note: The parameters in "()" belong to motors with brakes.

80 frame medium inertia motors

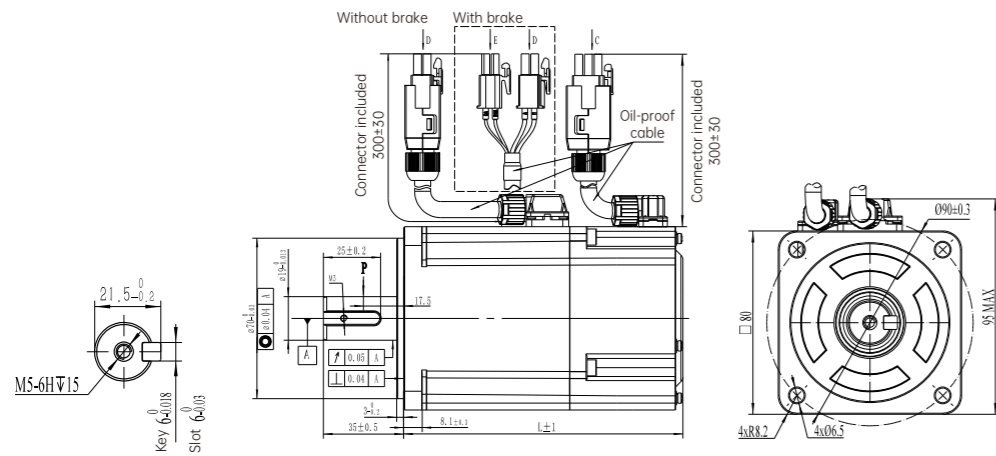

Model	L (mm)
SPM-SC60807M**-L	90(121.9)
SPM-SC80807M**-L	90(121.9)
SPM-SC60810M**-L	103.9(134.9)
SPM-SC80810M**-L	103.9(134.9)

Note: The parameters in "()" belong to motors with brakes.

130/180 medium inertia motors

Motor model	Rated voltage (V)	Rated power (W)	Rated speed (rpm)	Max. speed (rpm)	Rated torque (N·m)	Peak torque (N·m)	Rated current (A)	Peak current (A)	Rotor inertia (10 ⁻⁴ kg·m ²)
SPM-SE61311M**-W	220	1100	2000	4000	5.39	16.17	7.5	22.5	10.9(12.3)
SPM-SE61317M**-W	220	1700	2000	4000	8.34	25.22	12	36	16.9(18.3)
SPM-SC61317M**-W	220	1700	3000	5000	5.399	10.78	9.5	19	10.9(12.3)
SPM-TE61311M**-W	380	1100	2000	4000	5.39	16.17	4.5	13.5	10.9(12.3)
SPM-TE61317M**-W	380	1700	2000	4000	8.34	25.2	6.6	19.8	16.9(18.3)
SPM-TE61324M**-W	380	2400	2000	4000	9.5	28.5	11.5	34.5	21.4(22.6)
SPM-TE61330M**-W	380	3000	2000	4000	14.3	40	11.5	32.2	27.1(28.4)
SPM-TC61317M**-W	380	1700	3000	5000	5.399	10.78	9.5	19	10.9(12.3)
SPM-TC61326M**-W	380	2600	3000	5000	8.34	16.7	9.5	19	16.9(18.3)
SPM-TC61336M**-W	380	3600	3000	5000	11.5	23	12	24	18.3(21.4)
SPM-TC61345M**-W	380	4500	3000	5000	14.3	28.6	14.5	29	27.1(28.4)
SPM-TD11829M**-P	380	2900	1500	3000	18.6	54	11.9	34.5	44(59)
SPM-TD61829M**-P	380	2900	1500	3000	18.6	54	11.9	34.5	44(59)
SPM-TD11844M**-P	380	4400	1500	3000	28.4	71	16.5	41.3	66(80)
SPM-TD61844M**-P	380	4400	1500	3000	28.4	71	16.5	41.3	66(80)
SPM-TD11855M**-P	380	5500	1500	3000	35	87.5	21	52.5	102(110)
SPM-TD61855M**-P	380	5500	1500	3000	35	87.5	21	52.5	102(110)
SPM-TD11875M**-P	380	7500	1500	3000	48	96	25.5	51	146(156)
SPM-TD61875M**-P	380	7500	1500	3000	48	96	25.5	51	146(156)

Note: The parameters in "()" belong to motors with brakes.

130 frame medium inertia motors

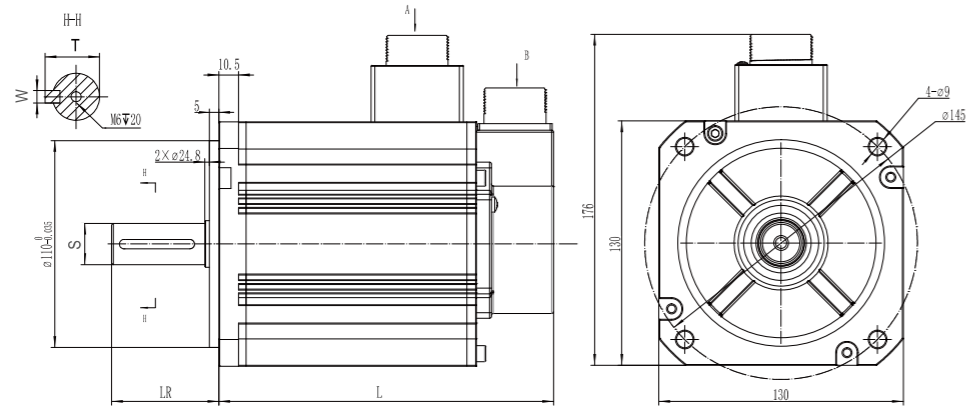

Model	L (mm)	LR (mm)	φS (mm)	W (mm)	T (mm)
SPM-SE61311M**-W	135(187)	57	22	6	24.5
SPM-SE61317M**-W	152.5(204)	57	22	6	24.5
SPM-SC61317M**-W	135(187)	57	22	6	24.5
SPM-TE61311M**-W	135(187)	57	22	6	24.5
SPM-TE61317M**-W	152.5(204)	57	22	6	24.5
SPM-TE61324M**-W	170(222)	57	22	6	24.5
SPM-TE61330M**-W	200(252)	57	22	6	24.5
SPM-TC61317M**-W	135(187)	57	22	6	24.5
SPM-TC61326M**-W	152.5(204)	57	22	6	24.5
SPM-TC61336M**-W	170(222)	57	22	6	24.5
SPM-TC61345M**-W	200(252)	57	22	6	24.5

Note: The parameters in "()" belong to motors with brakes.

180 frame medium inertia motors

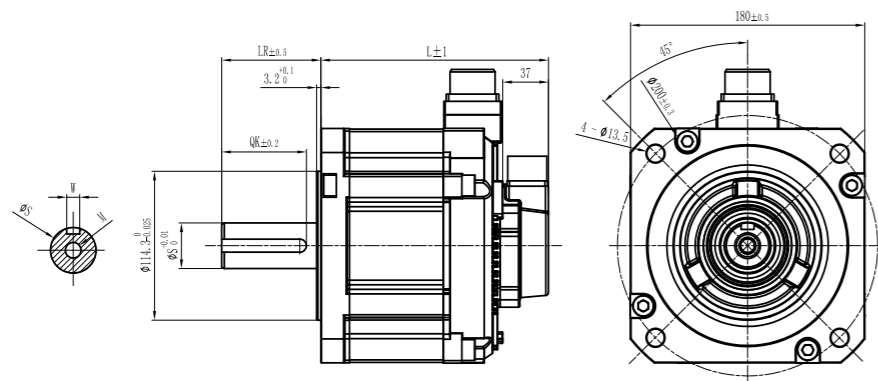

Model	L (mm)	LR (mm)	φS (mm)	W (mm)
SPM-TD11829M**-P	176(224)	79	35	10
SPM-TD61829M**-P	176(224)	79	35	10
SPM-TD11844M**-P	200(248)	79	35	10
SPM-TD61844M**-P	200(248)	79	35	10
SPM-TD11855M**-P	237(285)	113	42	12
SPM-TD61855M**-P	237(285)	113	42	12
SPM-TD11875M**-P	283(331)	113	42	12
SPM-TD61875M**-P	283(331)	113	42	12

Note: The parameters in "()" belong to motors with brakes.

Included Cables

No.	Model	Name	Description	Length	Diameter (mm ²)
1	SPL-MA04-xx-x	Main motor cable (60/80 frame)	Main motor cable, AMP female connector at the motor side	3/5/10 m	0.75
2	SPL-MA01-xx-x	Main motor cable (60/80 frame)	Main motor cable, straight pin aviation plug at the motor side	3/5/10 m	0.75
3	SPL-MC04-xx-x	Main motor cable (130 frame)	Main motor cable, straight pin aviation plug at the motor side	3/5/10 m	1.0
4	SPL-MD01-xx-x	Main motor cable (180 frame)	One end: AMP 4-core female connector The other end: straight terminal (SIZE B)	3/5/10 m	1.5
5	SPL-MD02-xx-x	Main motor cable (180 frame)	One end: AMP 4-core female connector The other end: U-type terminal (SIZE C)	3/5/10 m	2.5
6	SPL-E09-xx-x	Single-turn absolute encoder cable	One end: 3-row 15-core DB male connector The other end: 3-row 7-core AMP female connector	3/5/10 m	-
7	SPL-E07-xx-x	Multi-turn absolute encoder cable	One end: 3-row 15-core DB male connector The other end: 3-row 7-core AMP female connector	3/5/10 m	-
8	SPL-E01-xx-x	23-bit absolute encoder cable (60/80 frame)	One end: 3-row 15-core DB male connector The other end: 3-row 15-core DB male connector	3/5/10 m	-
9	SPL-E02-xx-x	23-bit absolute encoder cable (130/180 frame medium inertia)	One end: 3-row 15-core DB male connector The other end: 10-core aviation female connector	3/5/10 m	-
10	SPL-E11-xx-x	Incremental encoder cable (60/80 frame)	One end: 3-row 15-core DB male connector The other end: 3-row 15-core DB male connector	3/5/10 m	-
11	SPL-E12-xx-x	Incremental encoder cable (130/180 frame medium inertia)	One end: 3-row 15-core DB female connector The other end: 15-core aviation plug (SUNCHU)	3/5/10 m	-
12	SPL-B01-xx-x	Brake cable (60/80 frame)	One end: AMP 2-core female connector The other end: straight terminal	3/5/10 m	0.5
13	SPL-B02-xx-x	Brake cable (130/180 frame medium inertia)	One end: 3-core female straight aviation plug The other end: straight terminal	3/5/10 m	0.5
14	SPL-BMC04-xx-x	Brake & Power cable (130 frame medium inertia)	Main motor cable, straight pin aviation plug at the motor side, with brake	3/5/10 m	1.0

Note: "xx" indicates the cable length.

"x" indicates the flexible cable: R1 means 5 million times flexible cable and R2 means 10 million times flexible cable.